

SC2003 ROLLING STAGE

The SC2003 Rolling Stage has a retractable caster assembly to easily roll across a flat floor when completely assembled. The stage consists of a support structure and three 4' x 8' SC90 Platforms, creating an 8' x 12' area. Multiple rolling stages can bridge SC90 Platforms to create a larger performance area. When not in use, the support frames can be used as a platform storage cart (pictured below).



SC2003 Rolling Stage with Bridged Platforms



SC2003 Rolling Stage: 8' x 12'



Multi-Functional Support Frame used as Platform Storage Cart



ADVANTAGES

Efficiency

- “Bridges” platforms front to back and side to side, resulting in fewer supports for fast setup and strike.
- Locator nodes lock into place on each column and automatically align platforms; no need for readjustments.
- Setup easily by two people with no special tools
- For use with all of Staging Concepts’ platforms.

Adjustability

- Available in adjustable height ranges of 36” - 50” (914 mm - 1270 mm) and 48” - 72” (1219 mm - 1829 mm)
- Leveling feet allow for fine adjustment.

Durability

- Constructed of durable ERW carbon steel.
- Support structure has black powder coat finish to prevent rusting.

Storability

- Support frame able to be used as a storage cart for platforms when not setup as a stage.

TECHNICAL SPECIFICATIONS

The SC2003 Rolling Stage understructure, used with SC90®, SC97, Riser, Trex®, and Clima-Core™ Platforms, is designed to permit bridging of platforms between supports, and complies with the following:

- Adjustable heights: 36” - 50” (914 mm - 1270 mm) and 48” - 72” (1219 mm - 1829 mm)
 - Adjust course height by 4” (102 mm) increments using a 5/8” (16 mm) locking pin. Allow 3” (76 mm) additional fine height adjustment through use of integral acme thread adjustable screw foot.
- Capable of being erected without use of tools.
- Main vertical members: 2” (51 mm) OD by 12 gauge ERW carbon steel round mechanical tubing.
- Main horizontal members: 2” (51 mm) by 2” (51 mm) by 14 gauge carbon steel square tubing.
- Cross bracing: 0.1875” (5 mm) by 1” (25 mm) low carbon HR flat bar.
- Main pivot connection: aluminum casting, 380 aluminum alloy
- Casters: Design casters to meet the following:
 - Attach to base of understructure to ease the extension, closure and transport of understructure.
 - Engage and disengage using a lever arm handle.
 - Disengaging the casters will allow full support of the stage on main vertical columns.
 - Maximum lever handle force requirements shall meet OSHA regulations.

DIMENSIONS, WEIGHTS, AND FINISH OPTIONS

Dimensions:	(lbs/kg)
36” - 50” (914 mm x 1270 mm) adjustable height	550/249.5
48” - 72” (1219 mm x 1829 mm) adjustable height	600/272.2
*Custom sizes are available upon request	

Finish:

- Black powder coat

SC2003 ROLLING STAGE SCHEMATICS

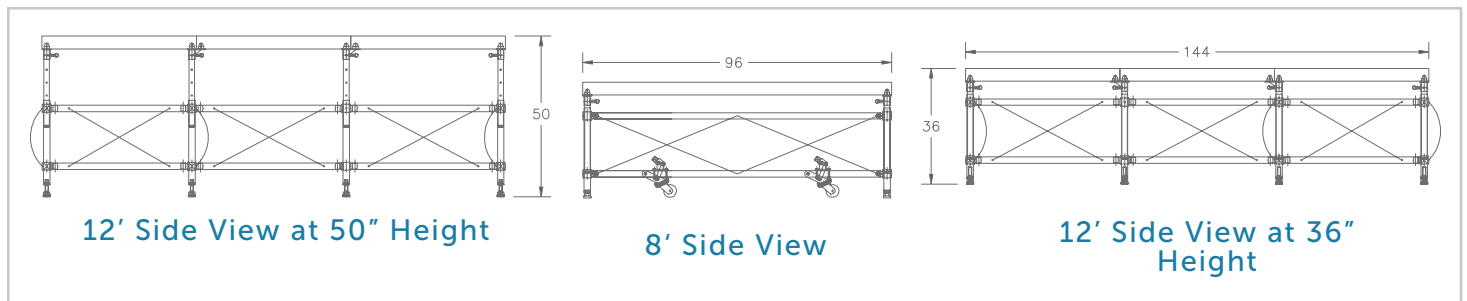

**STAGING
CONCEPTS**

A Trex® Company

We elevate all people’s abilities to safely access and enjoy amazing life experiences.

7008 Northland Drive · Suite 150 · Minneapolis, MN 55428 · www.stagingconcepts.com · 763.533.2094